

REVISION HISTORY			
REV	DESCRIPTION	DATE	APPROVED

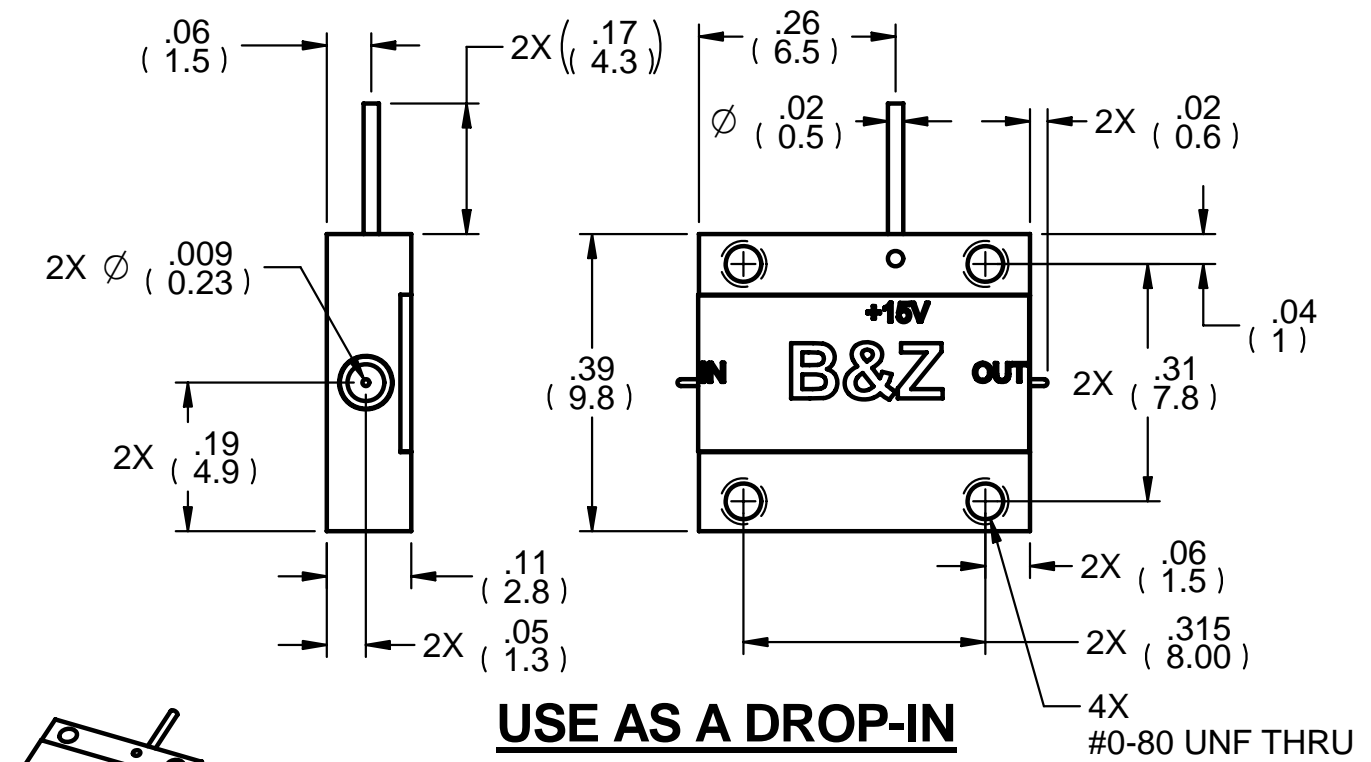

USE AS A DROP-IN

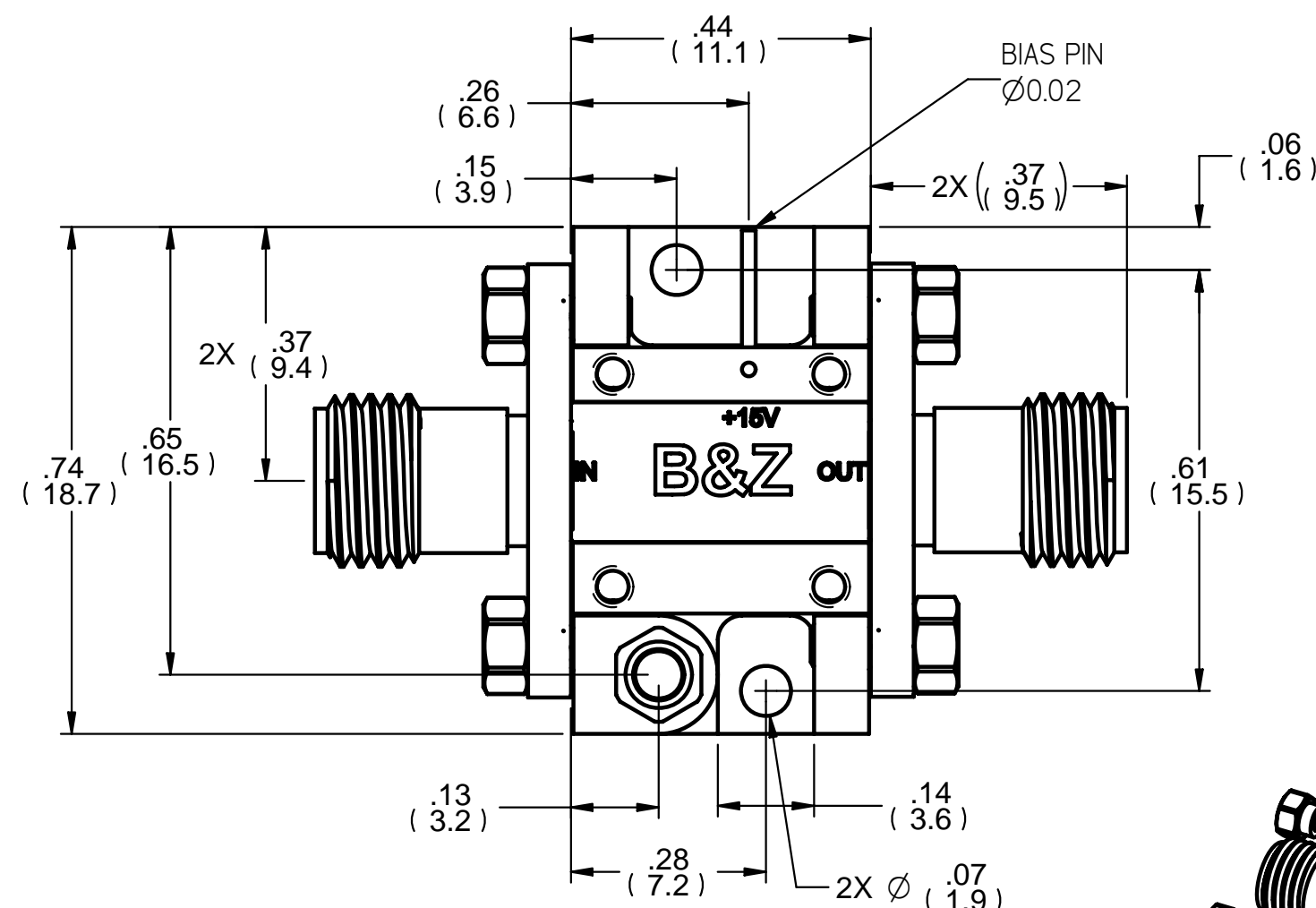
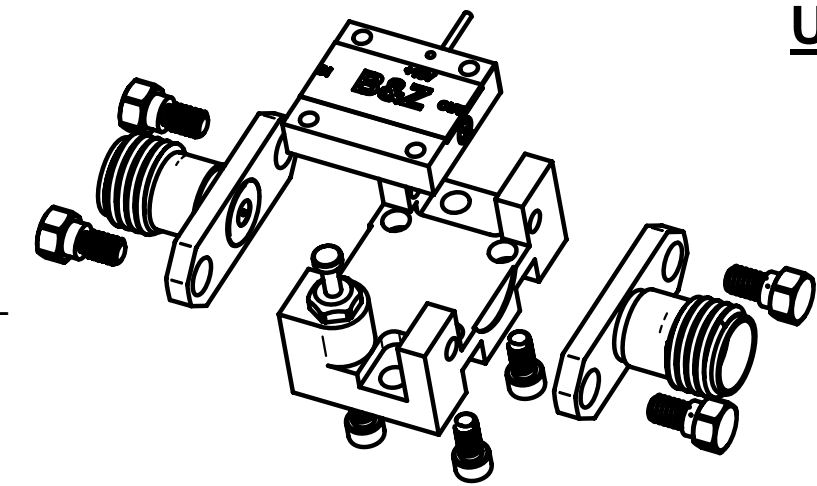
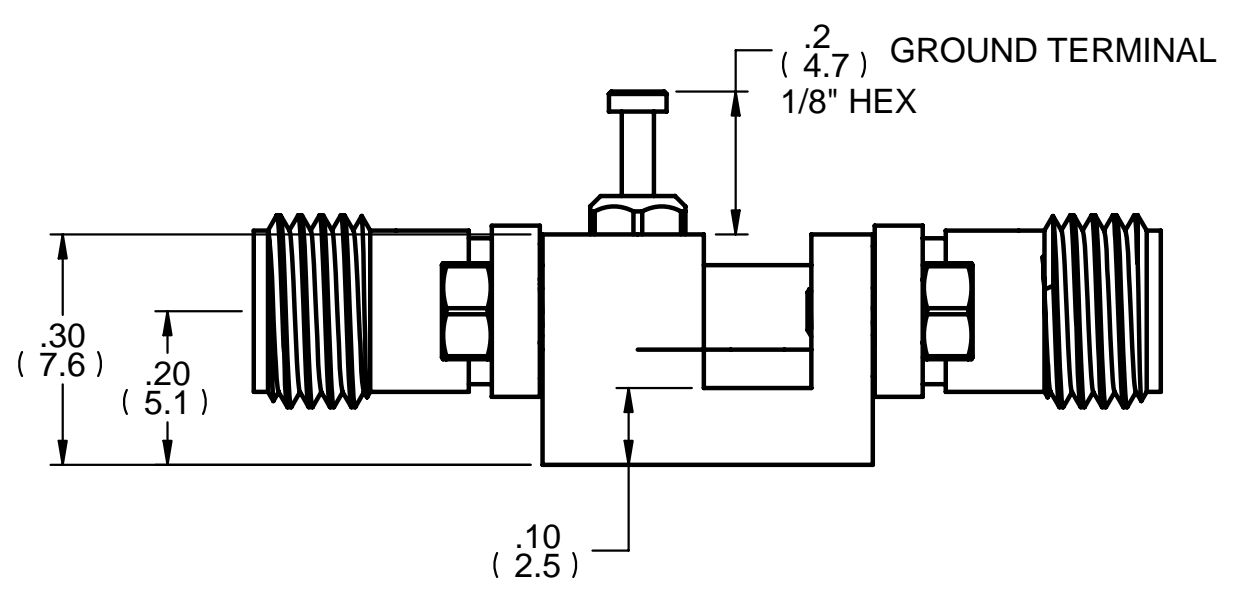

EXPLODED VIEW

SCREW EXAMPLE:
M9 X .225
SOURCE:
<http://www.morris01550.com/>

TOP MOUNTING

NAME	DATE	 STONY BROOK, NEW YORK 11790
DRAWN Dan S.	04/09/07	
CHECKED		
ENG APPR		
MGR APPR		TITLE
UNLESS OTHERWISE SPECIFIED DIMENSIONS ARE IN INCHES ANGLES ±0.05° 2 PL ±0.01 3 PL ±0.005		OUTLINE, STANDARD #10
SIZE B	DWG NO 100114	REV B
FILE NAME: 100114 A_OUTLINE, STANDARD #10.dft		
SCALE:	WEIGHT:	SHEET 1 OF 1