

5

4

3

2

1

REVISIONS				
ZONE	LTR	DESCRIPTION	DATE	APPROVED
	B	REDRAWN TO AGREE WITH MFD PARTS	1/7/14	

D

D

C

C

B

B

A

A

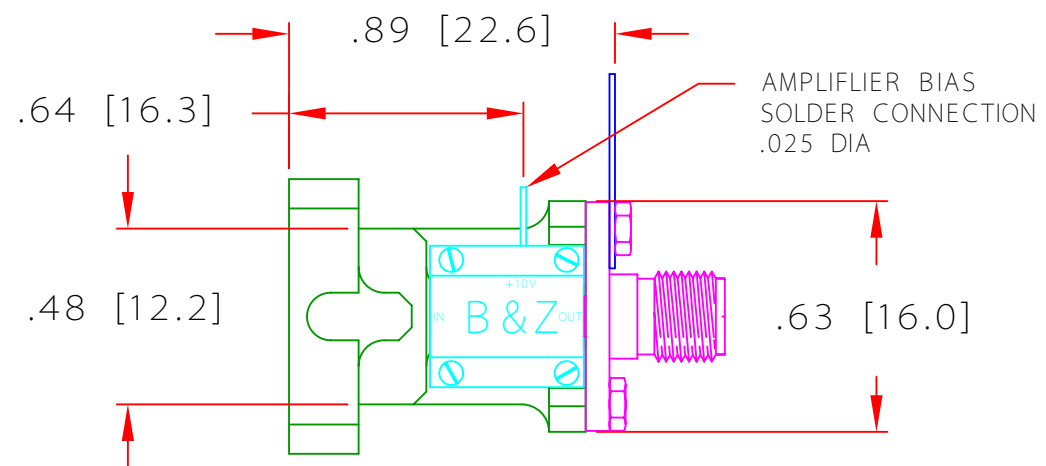

NOTES:

1. MATERIAL: BRASS 360 FREE MACHINING.
2. FINISH: ELECTROLESS NICKLE PER SAE AMS - C - 26074B .0001" TO .0002" PURE GOLD PER ASTM B 488 - 01 CODE A TYPE III .00005" .

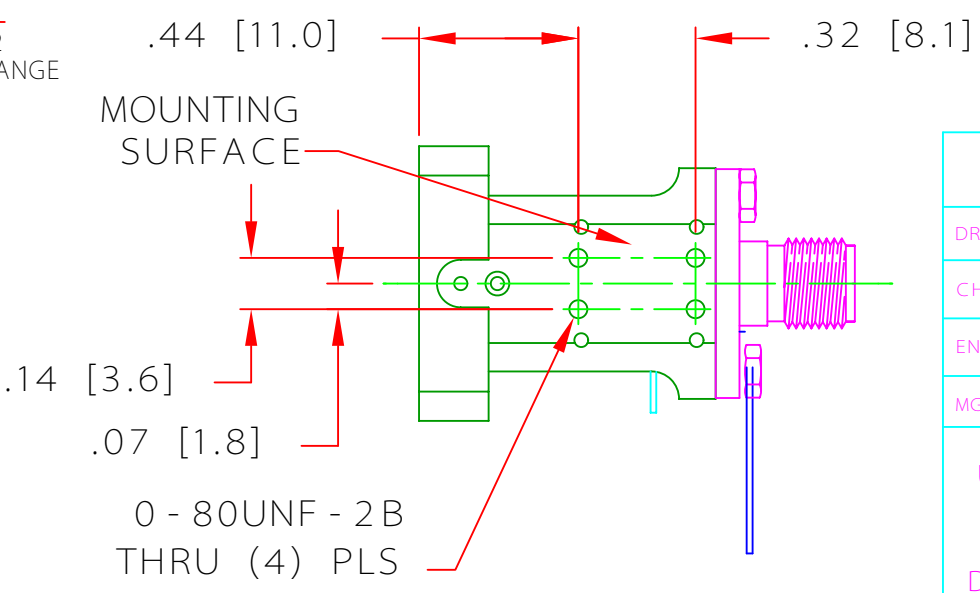
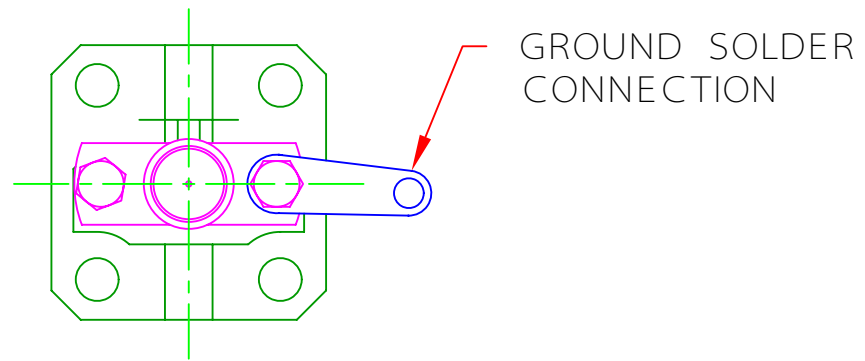
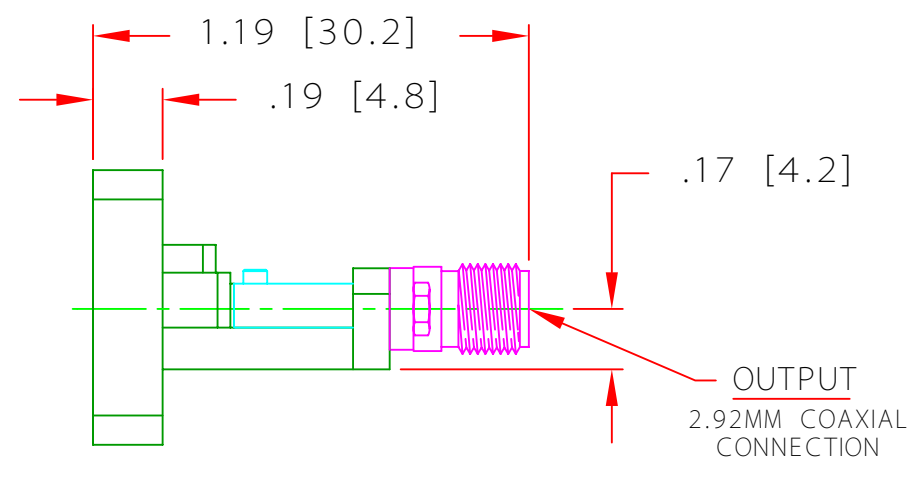
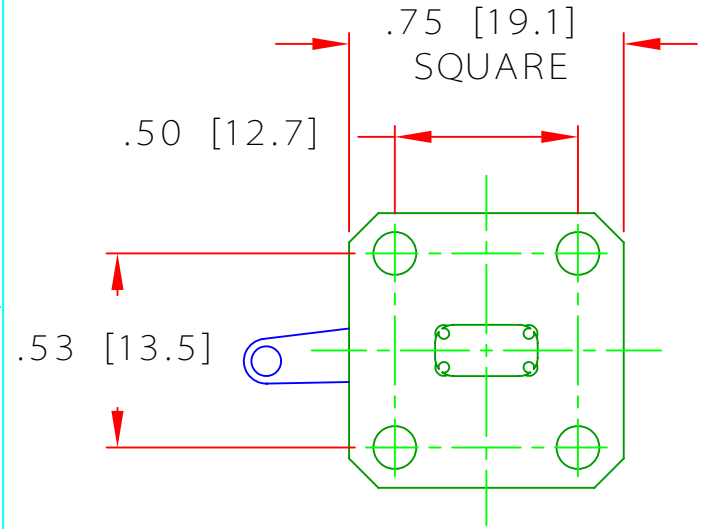

	NAME	DATE
DRAWN BY	MH	1/6/14
CHECKED BY		
ENG APPR		
MGR APPR		

B & Z TECHNOLOGIES
 STONYBROOK, NEW YORK 11790

TITLE:
OUTLINE DRAWING
WR - 22

UNLESS OTHERWISE SPECIFIED
 DIMENSIONS ARE IN INCHES
 TOLERANCES ON
 DECIMALS ANGLES
 .XX±.01 .XXX±.005 ±0°30'

SIZE	DWG NO.	REV.
B	100202	A

5

4

3

2

1